

# Паспорт



MODEL NUMBER \_\_\_\_\_

SERIES \_\_\_\_\_

SERIAL № \_\_\_\_\_

Части

Инструкция на английском языке

## Электрический распылитель для текстурированной окраски RTX 1500

*Максимальное рабочее давление воздуха (стандартная поставка): 45 psi (3,1 бар)  
Максимальное рабочее давление жидкости: 100 psi (6,9 бар)*



ОФИЦИАЛЬНЫЙ ДИСТРИБЬЮТОР И  
СЕРВИСНЫЙ ЦЕНТР GRACO В РОССИИ!

**ОКРАСОЧНОЕ ОБОРУДОВАНИЕ**  
ПРОЕКТИРОВАНИЕ, ПОСТАВКА, ОБСЛУЖИВАНИЕ



ООО «ТК Джeneral Инжиниринг»  
107023, г. Москва, ул. Малая Семёновская, д.11/2, строение 2

**+7 800 500 08 91**  
БЕСПЛАТНО ПО РОССИИ

✉ [info@gnrg.ru](mailto:info@gnrg.ru)



**[www.GNRG.RU](http://www.GNRG.RU)**

# Models

Model	Electric Requirements	Country	Manual			Languages
				287328*		
248201	120V, 60 Hz, 15 A	N. America	310624	310694	310616	English
248536	110V, 60Hz, 15A	UK	310624	310694	310616	English
248370 / 248315	230V, 50 Hz, 10 A	Europe	310624		310616	French
248370	230V, 50 Hz, 10 A	Europe	310624			Dutch
248370	230V, 50 Hz, 10 A	Europe	310625		310616	Spanish
248370 / 248315	230V, 50 Hz, 10 A	Europe	310625			Italian
248370	230V, 50 Hz, 10 A	Europe	310625			Portuguese
248370 / 248315	230V, 50 Hz, 10 A	Europe	310625			German
248315	230V, 50 Hz, 10 A	Europe	310697			Swiss
248315	230V, 50 Hz, 10 A	Europe	310697			Danish
248370	230V, 50 Hz, 10 A	Europe	310697			Norwegian
248370	230V, 50 Hz, 10 A	Europe	310697			Swedish
248370	230V, 50 Hz, 10 A	Europe	310698			Polish
248370	230V, 50 Hz, 10 A	Europe	310698			Russian
248370	230V, 50 Hz, 10 A	Europe	310698			Greek
248315	230V, 50 Hz, 10 A	Asia	310699			Chinese
248315	230V, 50 Hz, 10 A	Asia	310699			Japanese
248315	230V, 50 Hz, 10 A	Asia	310699			Korean
248315	230V, 50 Hz, 10 A	Australia	310699	310694	310616	English

Auxiliary Air Hookup Kit





## RELATED MANUALS



Model	Country		Manual	Languages
ALL	ALL		310645	English

The following are general Warnings related to the safe setup, use, maintenance and repair of this equipment. Additional, more specific warnings may be found throughout the text of this manual where applicable.

# Warnings

The following warnings are for the setup, use, grounding, maintenance, and repair of this equipment. The exclamation point symbol alerts you to a general warning and the hazard symbols refer to procedure-specific risks. When these symbols appear in the body of this manual, refer back to these Warnings. Product-specific hazard symbols and warnings not covered in this section may appear throughout the body of this manual where applicable.

 <b>WARNING</b>	
	<p><b>Fire and Explosion Hazard</b> Flammable fumes, such as solvent and paint fumes, in work area can ignite or explode. To help prevent fire and explosion:</p> <ul style="list-style-type: none"> <li>• Use equipment only in well ventilated area.</li> <li>• Keep work area free of debris, including solvent, rags, and gasoline.</li> <li>• Ground equipment in the work area. See <b>Grounding</b> instructions.</li> <li>• If there is static sparking or you feel a shock, <b>stop operation immediately</b>. Do not use equipment until you identify and correct the problem.</li> </ul>
	<p><b>Equipment Misuse Hazard</b> Equipment misuse can cause death or serious injury.</p> <ul style="list-style-type: none"> <li>• Do not exceed maximum working pressure or temperature rating of lowest rated system component. See <b>Technical Data</b>, in all equipment manuals.</li> <li>• Use fluids and solvents that are compatible with equipment wetted parts. See <b>Technical Data</b> in all equipment manuals. Read fluid and solvent manufacturer's warnings.</li> <li>• Check equipment daily. Repair or replace worn or damaged parts immediately.</li> <li>• Do not alter or modify this equipment.</li> <li>• Use the equipment only for its intended purpose. Call your Graco distributor for information.</li> <li>• For professional use only.</li> <li>• Route hoses away from traffic areas, sharp edges, moving parts and hot surfaces.</li> <li>• Do not use hoses to pull equipment.</li> <li>•</li> <li>• Comply with all applicable safety regulations.</li> </ul>
	<p><b>Electric Shock Hazard</b> Improper grounding, setup, or usage of the system can cause electric shock.</p> <ul style="list-style-type: none"> <li>• Turn off and disconnect power cord before servicing equipment.</li> <li>• Use only grounded electrical outlets.</li> <li>• Use only 3-wire extension cords.</li> <li>• Ensure ground prongs are intact on sprayer and extension cords.</li> </ul>

 <b>WARNING</b>	
	<p><b>SKIN INJECTION HAZARD</b></p> <p>High-pressure fluid from gun, hose leaks, or ruptured components will pierce skin. This may look like just a cut, but it is a serious injury that can result in amputation. <b>Get immediate surgical treatment.</b></p> <ul style="list-style-type: none"> <li>• Do not point gun at anyone or at any part of the body.</li> <li>• Do not put your hand over the spray tip.</li> <li>• Do not stop or deflect leaks with your hand, body, glove, or rag.</li> <li>• Do not spray without tip guard and trigger guard installed.</li> <li>• Engage trigger lock when not spraying.</li> <li>• Follow <b>Pressure Relief Procedure</b> in this manual, when you stop spraying and before cleaning, checking, or servicing equipment.</li> </ul>
	<p><b>Cleaning Solvent Hazard with Plastic Parts</b></p> <p>Use only compatible water-based solvents to clean plastic structural or pressure-containing parts. Many solvents can degrade plastic parts to the point where they could fail. Such failure could cause serious injury or property damage. See <b>Technical Data</b> on page 34 of this instruction manual and in all other equipment manuals. Read fluid and solvent manufacturer's warnings.</p>
	<p><b>Moving Parts Hazard</b></p> <p>Moving parts can pinch or amputate fingers and other body parts.</p> <ul style="list-style-type: none"> <li>• Keep clear of moving parts.</li> <li>• Do not operate equipment with protective guards or covers removed.</li> <li>• Pressurized equipment can start without warning. Before checking, moving, or servicing equipment, follow the <b>Pressure Relief Procedure</b> in this manual. Disconnect power or air supply.</li> </ul>
	<p><b>Personal Protective Equipment</b></p> <p>Wear appropriate protective equipment when operating, servicing or when in the operating area of this equipment to help protect yourself from serious injury, including eye injury, inhalation of toxic fumes, burns and hearing loss. This equipment includes, but is not limited to:</p> <ul style="list-style-type: none"> <li>• protective eye wear</li> <li>• clothing and respirator as recommended by fluid and solvent manufacturer</li> <li>• hearing protection</li> <li>• gloves</li> </ul>
	<p><b>CALIFORNIA PROPOSITION 65</b></p> <p>The engine exhaust from this product contains a chemical known to the State of California to cause cancer, birth defects or other reproductive harm.</p>

<b>NOTICE</b>	
<p>Water or material remaining in unit when temperatures are <b>below freezing</b> can damage pump and/or delay startup. To insure water and material are completely drained out of unit:</p> <ul style="list-style-type: none"> <li>• Remove hose from material outlet,</li> <li>• Tip sprayer forward 45° to allow material (water) to flow out of pump inlet.</li> <li>• Before adding material or starting unit in cold weather, circulate warm water through pump.</li> </ul>	

# Component Identification

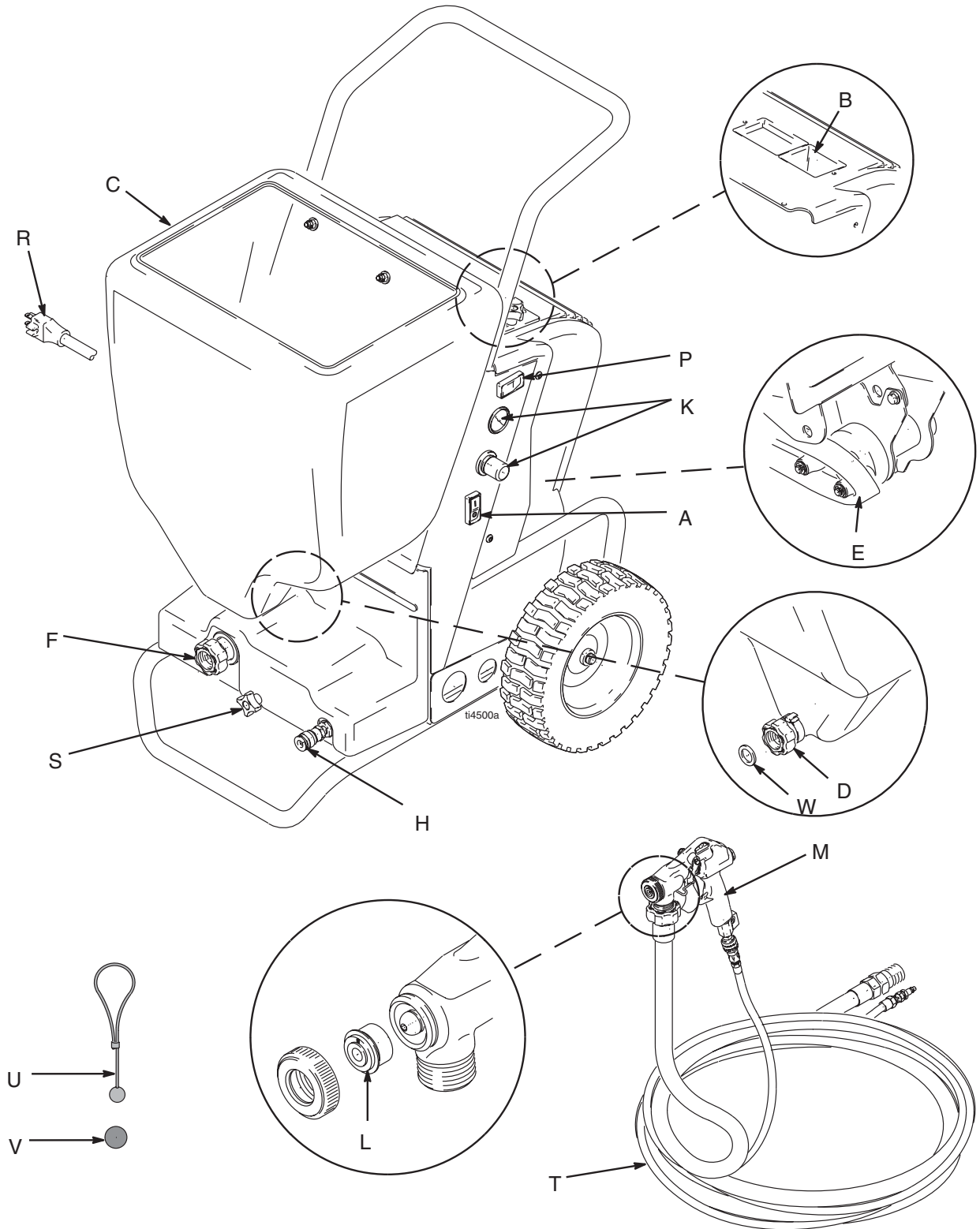

# Component Identification

<b>ITEM</b>	<b>COMPONENT</b>
A	Main Power Switch
B	Nozzle Storage
C	Hopper
D	Hopper Connect/Disconnect
E	Graco RotoFlex™ HD Pump
F	Material Outlet
H	Air Outlet
K	Fluid Flow Regulator and Pressure Gauge
L	Gun Nozzle (5 sizes)
M	Gun (see manual 310616)*
P	Prime Switch
R	Power Cord
S	Pump Access Screw
T	Hose - 25-ft.
U	Material Thickness Gauge
V	Cleaning Ball
W	Spare Hose Gaskets

# Preparation

## Pressure Relief Procedure

1. Turn Main Power Switch (A) OFF.

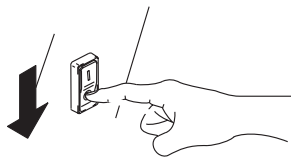

2. Turn fluid flow regulator (K) all the way down to reduce pressure.

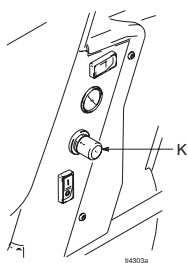

3. Open gun air valve (aa).

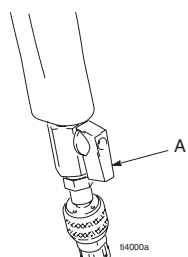

4. Trigger gun, spraying material back into hopper (C).

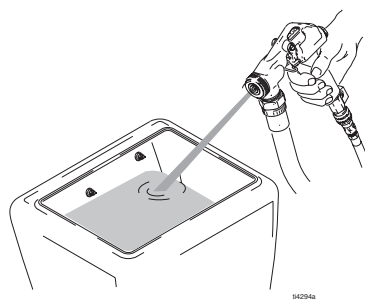

## Grounding and Electric Requirements

The sprayer must be grounded. Grounding reduces the risk of electrical shock by providing an escape wire for the electrical current.

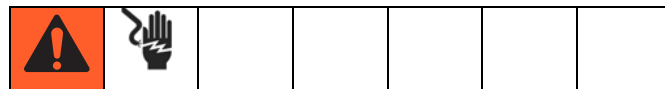

- The sprayer cord includes a grounding wire with an appropriate grounding prong.

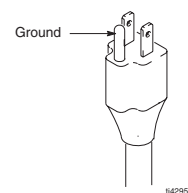

- The plug must be plugged into an outlet that is properly installed and grounded in accordance with all local codes and ordinances.

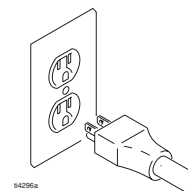

- Do not modify plug! If it will not fit in outlet, have grounded outlet installed by a qualified electrician.

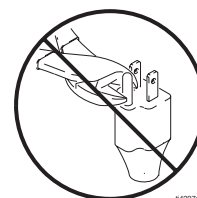

- Sprayer model electric requirements are provided on page 2.

### Extension Cords

- Only use an extension cord with an undamaged 3-prong plug.
- For up to 100 ft (30.48 m) cord, use 3-wire, 12 AWG (2.5 mm<sup>2</sup>) minimum.

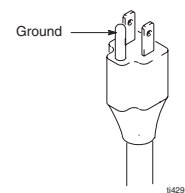

## Auxiliary Air Compressor

- Use Auxiliary Air Hookup Kit 287328 when additional atomization air is necessary.

### **NOTICE**

Attaching auxiliary air to sprayer without using the Auxiliary Air Hookup Kit will damage sprayer.

## Generators

7500 W (7.5 KW) minimum.

### Tips for Using Generators

- Before running sprayer, make sure it is at room temperature. This will reduce startup current.
- Run generator at full throttle.

## Hose Lengths

- The system comes with a twin line hose set consisting of a 1 in. ID x 25 ft (25 mm x 7.6 m) material hose and a 3/8 in. ID air hose. Additional hose sections can be added. Total final length of hose used should not exceed 100 feet in length.

### **NOTICE**

Sprayer air hose fitting can get hot! Allow sprayer to cool down 5 minutes before removing air hose.



# Removing and Replacing Hopper, Front and Back Covers

**Before performing any service on sprayer always:**

- Read all warnings, page 3.
- Read operating instructions manual, page 2.
- **Relieve Pressure**, page 7.
- Turn main power switch (A) OFF.
- Unplug sprayer from outlet.
- Remove air and material hoses.
- Clean sprayer. See Operation Manual 310624 or 310625.

## Hopper

### Removing Hopper

1. To remove hopper loosen fitting. Fittings are hand-tightened and should not require tools to loosen.
2. Lift hopper straight up, off frame.

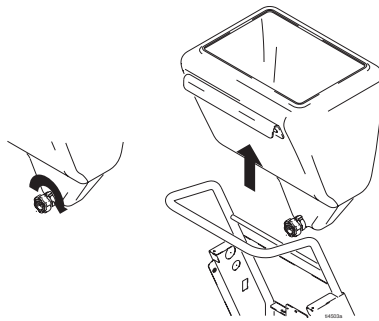

### Replacing Hopper

1. To replace hopper, position drain over fitting as far as it will go, making sure identification label faces out.
2. Hand tighten fitting.

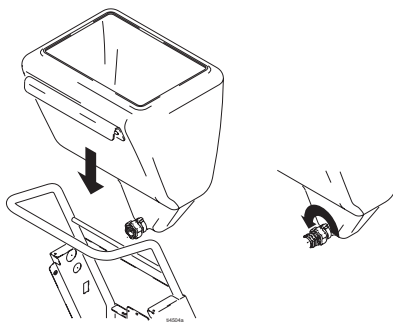

## Front Cover

### Removing Cover

1. Remove hopper.
2. Unscrew and remove knob (S).
3. Place your hand under front, bottom edge of cover. **(3a)** Lift cover up, **(3b)** then pull bottom toward you and out to remove cover.

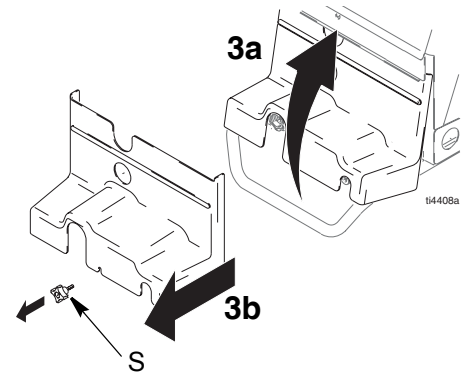

### Replacing Cover

1. Place your hand under front, bottom edge of cover. **(1a)** Position top edge of cover under top metal lip on sprayer frame. **(1b)** Then push up on cover so lower plastic edge of cover has room to clear front metal frame and slide cover into place. To position cover correctly, it will go in at an angle.
2. Replace knob (S). Hand tighten fitting.
3. Replace hopper.

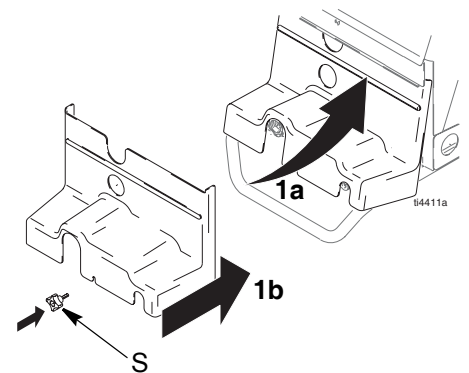

## Back Cover

To access the motor and all other components, it is necessary to remove the hopper, front and back covers.

### Removing Cover

1. Completely remove 6 screws (2 on top and each side) from cover.

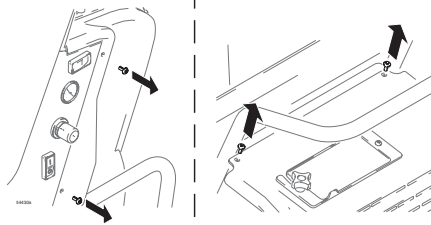

2. Lift cover up and then tilt it back and off sprayer frame.

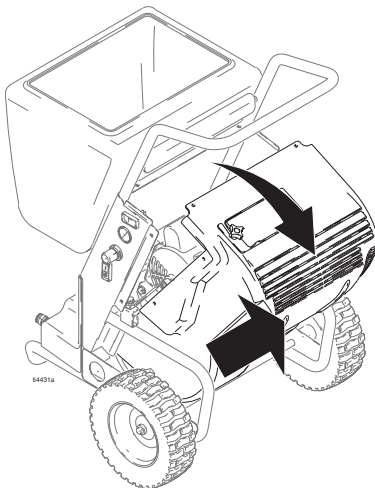

### Replacing Cover

1. To reposition cover on sprayer frame, tip the cover back, toward you and slide it down, into place in the base of the frame. Then push the top back into place. Align screw holes in side and top of cover with holes in frame.

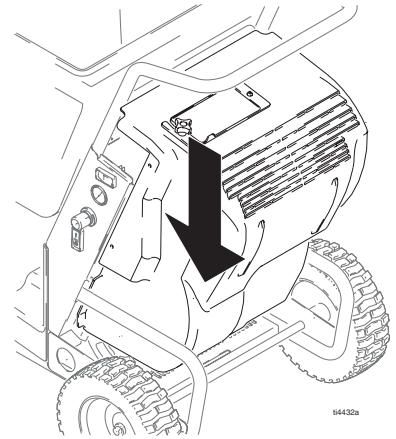

2. Replace and tighten screws.

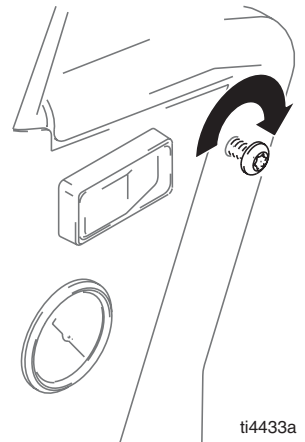

# RotoFlex™ HD Pump

Use RotoFlex HD Pump Replacement Kit 287314.

**NOTE:** After replacing RotoFlex HD Pump hose, always follow Hose Break-In Procedure, page 13, before operating sprayer.

## Disassembly

First read and follow instructions in the **Before performing any service on sprayer** section, page 9.

Then remove hopper and front cover, page 9.

1. Loosen and remove hose extension.



t14377a

2. Loosen and remove knob.

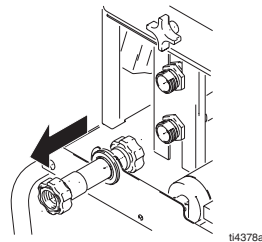

t14378a

3. Slide RotoFlex HD hose off rollers.

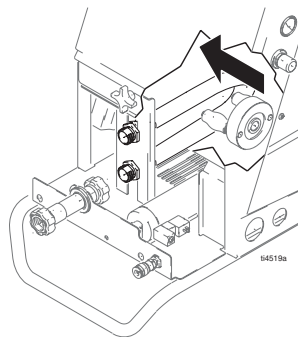

t14518a

4. Rotate pump assembly sideways. Pull entire assembly out of front of sprayer frame.

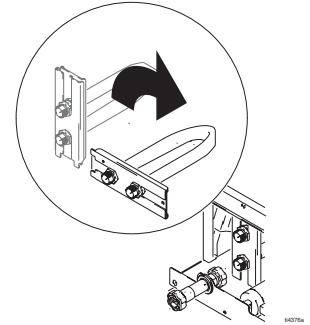

5. Separate the inner and outer hose brackets.

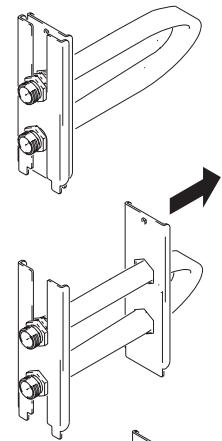

6. Slide hose ends out of slots in outer hose bracket (slide out of short slot first).

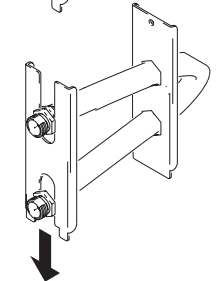

7. Pull hose out of inner hose bracket.

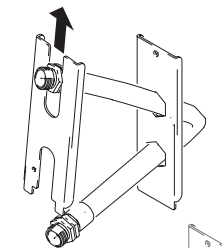

8. Discard pump hose.

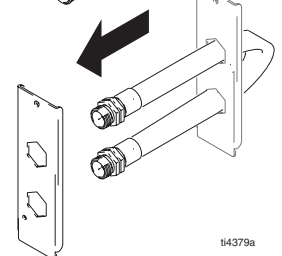

t14379a

## Reassembly

1. Bend and kink new pump hose from kit in the middle as shown, making sure dots on hose fittings face each other.

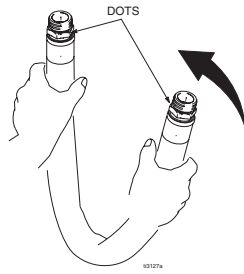

2. Insert hose ends through holes in inner hose bracket, keeping dots on fittings facing each other and kinked portion of hose horizontal to the underside of bracket.

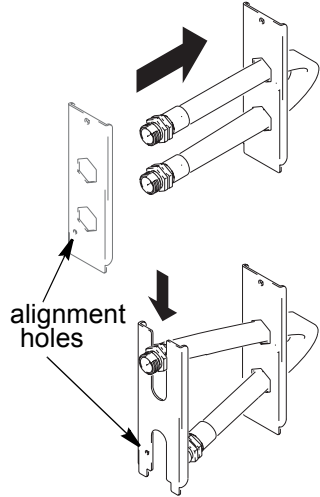

3. Slide hose ends into outer hose bracket, making sure dots on fittings face each other and alignment holes are together (slide into long slot first).

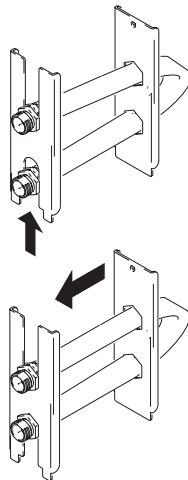

4. Slide plates together, inserting inner plate in outer plate, matching alignment holes.

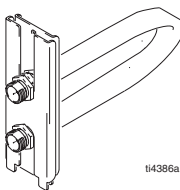

5. Replace bracket assembly in housing making sure the mounting screw hole, located in the top center of the inner plate, faces up.

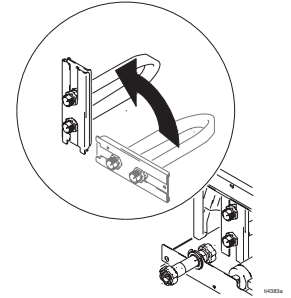

6. Slide pump hose around rollers. Make sure the rollers are horizontally parallel to each other.

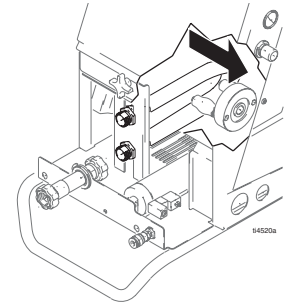

7. Slide feet on the bottom of hose bracket, into the slot on the bottom of sprayer.

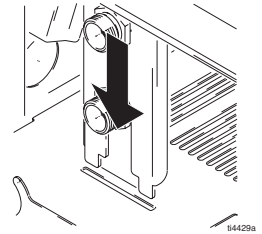

8. Replace knob. Hand tighten.

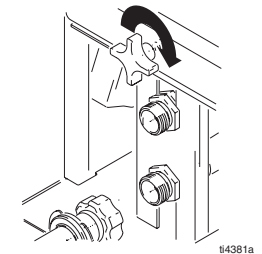

9. Reattach hose extension.

10. Replace front cover and hopper. See Removing and Replacing Hopper, Front and Back Cover, page 9.

## Hose Break-In Procedure

1. Make sure fluid flow regulator (K) is turned all the way down.

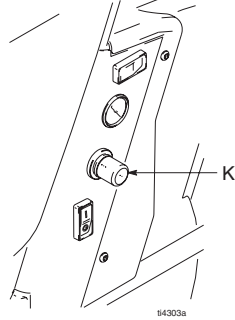

2. Pour approximately 1 gallon **hot** water in sprayer hopper to lubricate the pump.

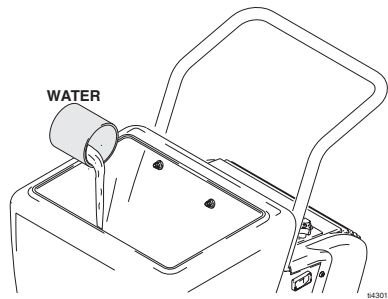

3. Turn power switch (A) on.

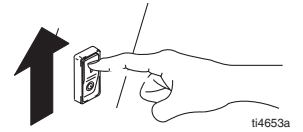

4. Hold in prime switch (P).

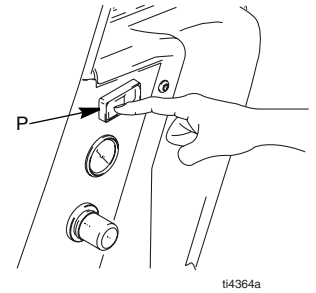

5. Turn fluid flow regulator (K) up to full pressure.
6. Run sprayer dry for 1 to 1-1/2 minutes.

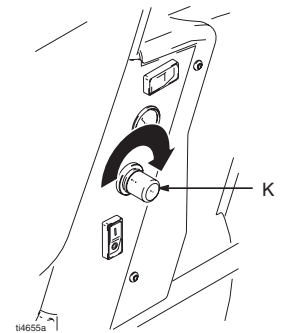

# Compressor and Motor Repair

For 120 V sprayer use Compressor and Motor Replacement Kit, 287315.

For 230 V sprayer use Compressor and Motor Replacement Kit, 287344.

Kits include motor/compressor and mounting hardware.

## Disassembly

First read and follow instructions in the **Before performing any service on sprayer** section, page 9.

Then remove hopper, front and back covers, page 9.

Remove hose extension and RotoFlex HD Pump assembly from frame, page 11.

1. Remove two screws and access cover on the left side of the motor.

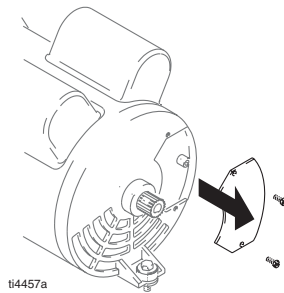

2. Remove ground nut and disconnect green ground wire.

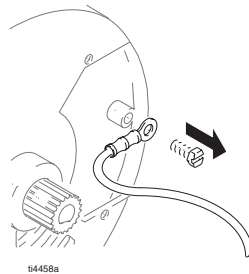

3. Disconnect black and white wires to motor.

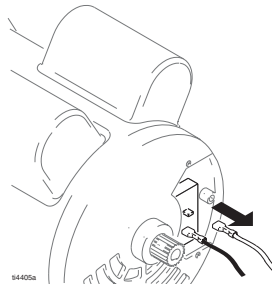

4. Loosen 4 bolts (2 each side) to loosen tension on belt.

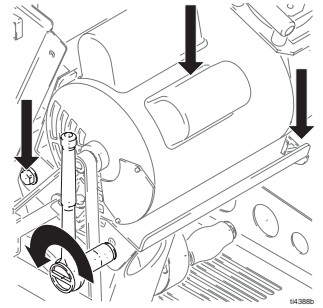

5. Slide belt off motor pulley.

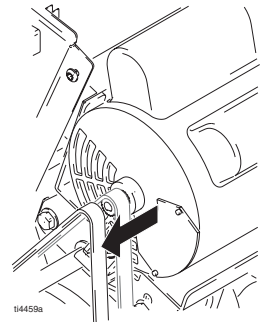

6. Disconnect air line from compressor to cooler and remove.

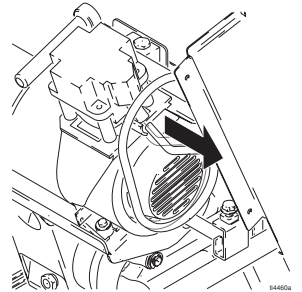

7. Remove 3 screws on right side of cover and remove cover.

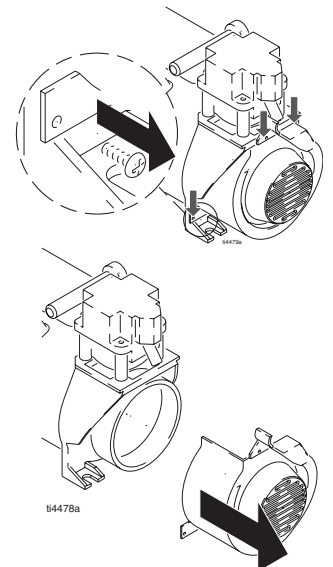

- Loosen 2 shoulder bolts about 2-3 turns. Do not remove them.

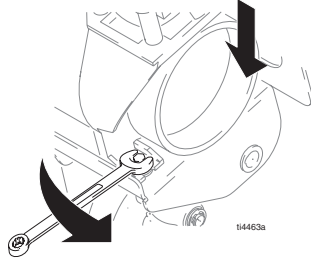

- Remove single shoulder bolt on other side of motor completely.

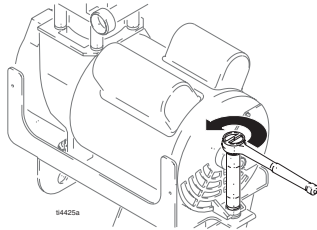

- Slide out motor assembly.

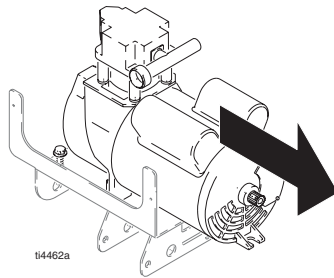

- Completely remove old shoulder bolts and rubber mounts.

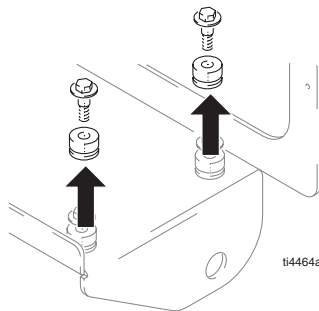

- Thoroughly clean inside housing to remove dust and debris.

## Reassembly

- Using two new shoulder bolts and rubber mounts included in your kit, insert bolts into openings until they start to snug up on rubber mounts.

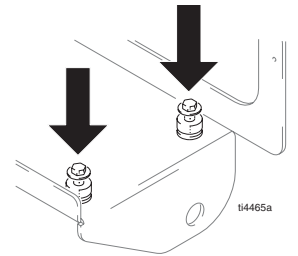

- Slide new motor into sprayer frame, aligning motor frame opening under bolts. Tighten bolts.

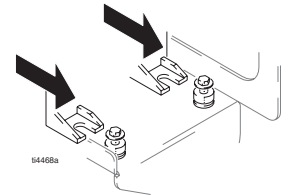

- Replace shoulder bolt on left side with new bolt from your kit. Tighten bolt.

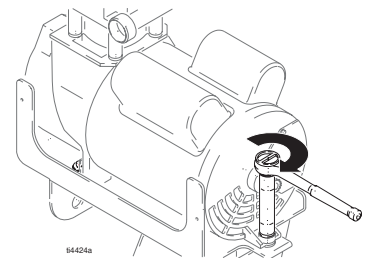

- Replace end cover. Replace and tighten 3 screws.

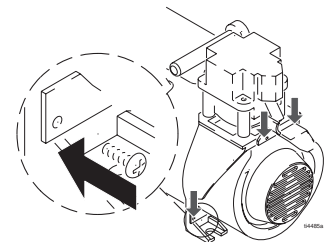
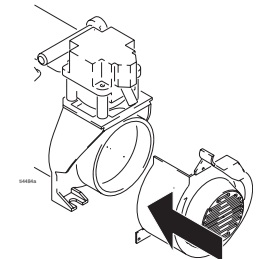

- Reattach air line to cooler and compressor. Tighten fitting.

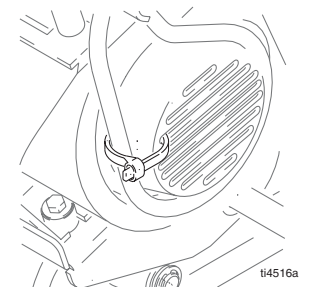

- Slide belt over pulleys and set tension. See Replacing Belt, page 19.

7. Reattach black and white wires to motor.

**NOTE:** Wires are not polarity sensitive.

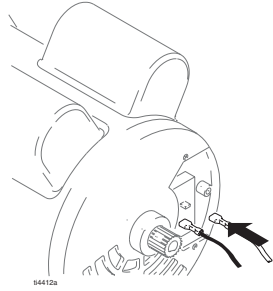

8. Reattach green ground wire and grounding nut.

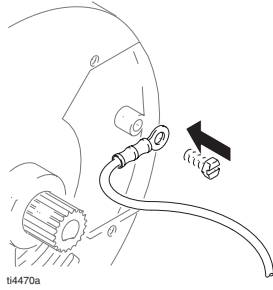

9. Replace cover plate and screws.

10. Replace RotoFlex HD Pump and hose extension, page 12.

11. Replace front and back covers and hopper. See Removing and Replacing Hopper, Front and Back Cover, page 9.

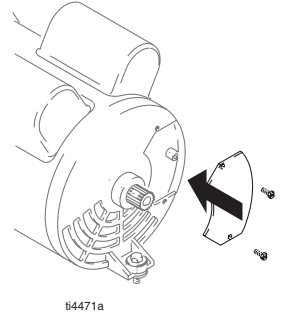



# Compressor Rebuild Kit

To replace piston, seals and sleeve.

For 120 V sprayer use Compressor Rebuild Kit 287330.

For 230 V sprayer use Compressor Rebuild Kit 287331.

## Disassembly

First read and follow instructions in the **Before performing any service on sprayer** section, page 9.

Then remove back cover, page 9.

1. Disconnect air line to motor.

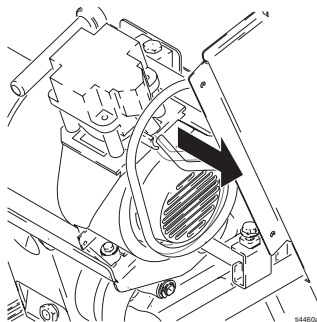

2. Remove 3 screws in side of motor cover. Remove cover.

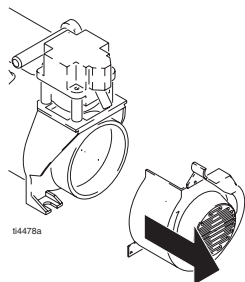
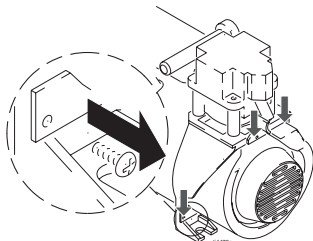

3. Remove fan bolt from center of fan and remove fan from housing.

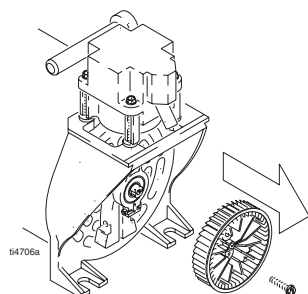

4. Remove 3/8 in. bolt holding piston to motor shaft.

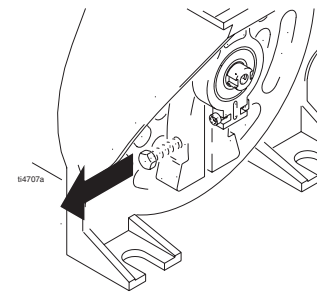

5. Loosen 4 bolts on top of motor housing.

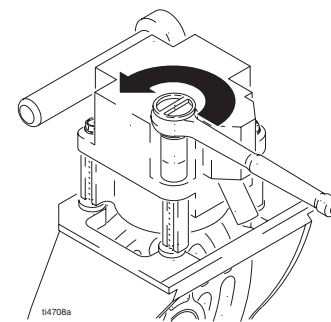

6. Remove bolts and housing from motor.

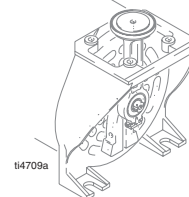
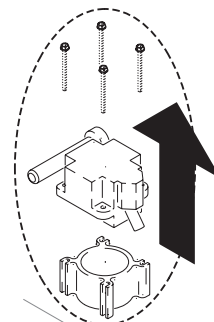

7. Remove piston rod from motor.

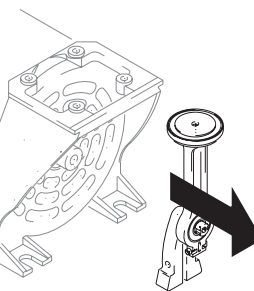

8. Using parts in kit replace piston, seals and sleeve.

## Reassembly

1. Insert new piston rod from kit in motor housing.

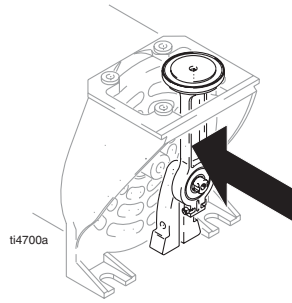

2. Replace and tighten piston bolt.

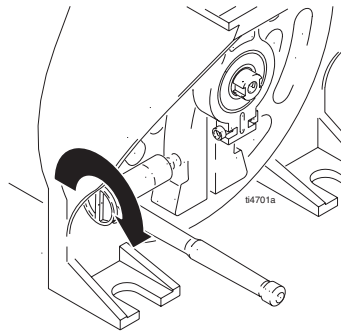

3. Replace top motor housing and 4 bolts.

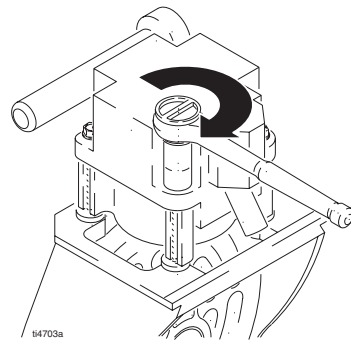

4. Tighten bolts.

5. Replace motor fan and center fan bolt.

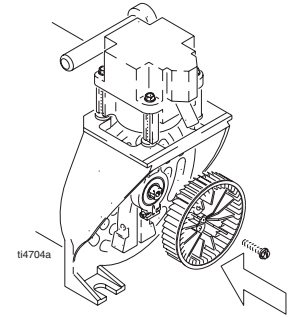

6. Tighten bolt.

7. Replace motor cover and screws.

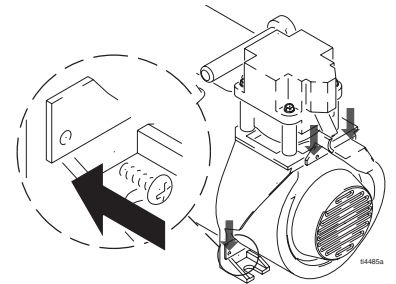

8. Reconnect air line from motor to cooler.

9. Replace back cover. See Removing and Replacing Hopper, Front and Back Cover, page 9.

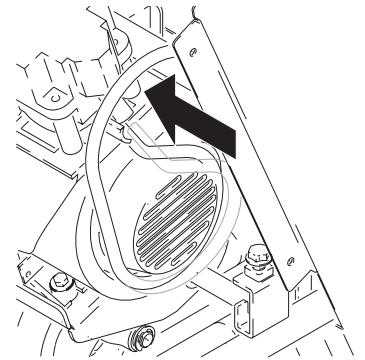

# Removing and Replacing Belt

Use Belt Replacement Kits 118845.

First read and follow instructions in the **Before performing any service on sprayer** section, page 9.

Then remove hopper, front and back covers, page 9.

Remove hose extension and RotoFlex HD Pump assembly from frame, page 11.

## Removing Belt

1. Loosen 4 bolts (2 each side) to loosen tension on belt.

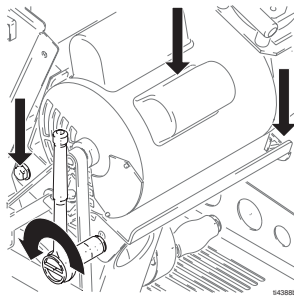

2. Loosen 2 bolts (1 each side) holding down support rod.

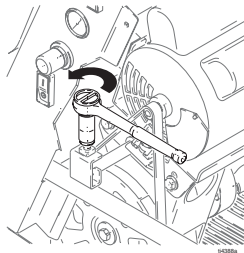

3. Using a screw driver for leverage, lift up on motor support rod on one side of motor and ease it out of the holding bracket far enough to remove old belt. Discard old belt.

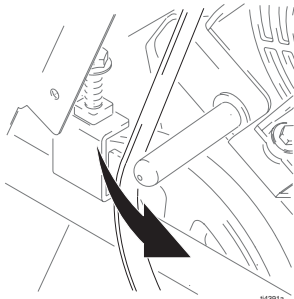

At the same time, slide in the new belt.

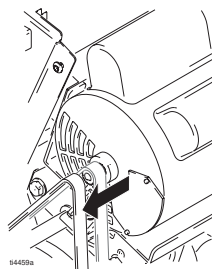

## Replacing Belt

1. Using new belt from Kit, position new belt around pulleys making sure the teeth in the belt are properly engaged with teeth on pulleys.

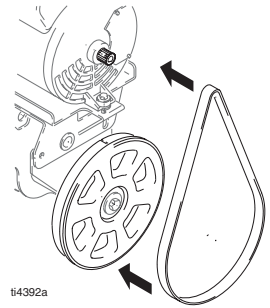

2. Replace support rod. Tighten 2 bolts (1 each side) to secure supporting rod.

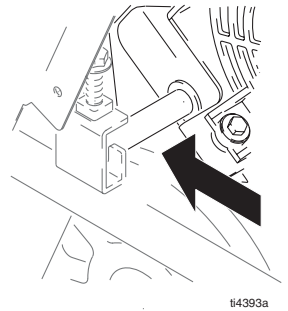

3. Insert crow bar under assembly as shown and raise motor assembly until desired belt tension is achieved.

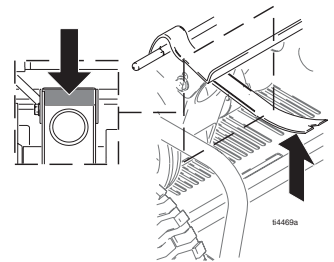

4. While holding motor assembly in place with crow bar. Spin pulley to assure proper belt engagement. Adjust motor assembly position as necessary.

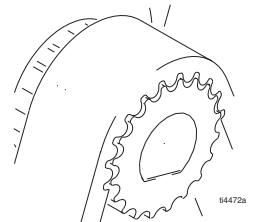

**NOTE:** A correctly tensioned belt will feel very tight. To measure correct tension apply 4-5 lbs pressure at belt midpoint with thumb. Belt should have approximately 1/8 in (3.175 mm) deflection.

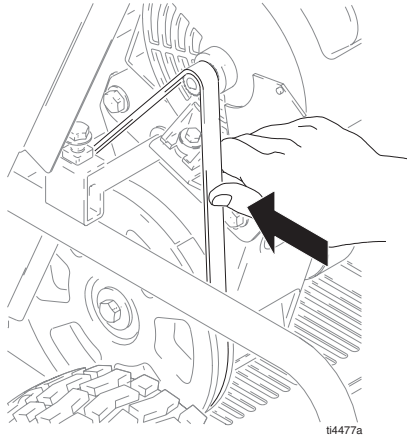

**NOTE:** A loose belt will not last long. If in doubt, tighten more.

5. Tighten all 4 bolts.

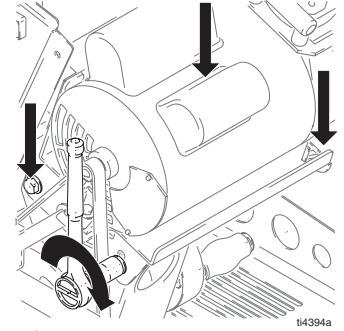

6. Turn belt one more time with your hand to make sure teeth are properly engaged and tension is correct.

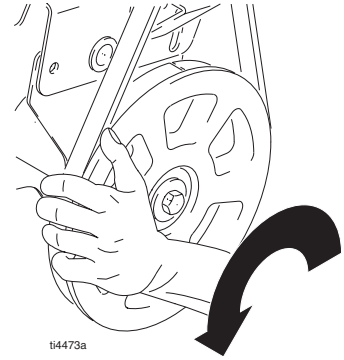

7. Replace RotoFlex HD Pump and hose extension, page 12.

8. Replace back and front covers and hopper. See Removing and Replacing Hopper, Front and Back Cover, page 9.

# Roller Replacement

Use Roller Replacement Kit 287321.

Kit includes 2 rollers, 4 nylon washer, and 2 retaining rings.

## Disassembly

First read and follow instructions in the **Before performing any service on sprayer** section, page 9.

Then remove hopper, front and back covers, page 9.

Remove hose extension and RotoFlex HD Pump assembly from frame, page 11.

1. Remove snap ring.



2. Remove roller assembly from rotor pins (a).

3. Clean rotor pins (a) and check for damage. If pins are worn or damaged, replace rotor assembly, (Rotor Assembly Replacement, page 22).

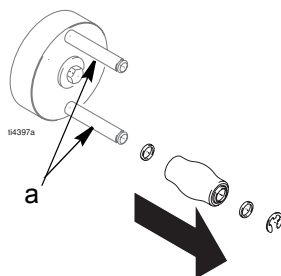

## Reassembly

1. Replace roller assembly.

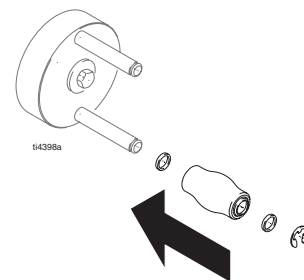

2. Reinstall snap ring.

3. Replace RotoFlex HD Pump and hose extension, page 12.

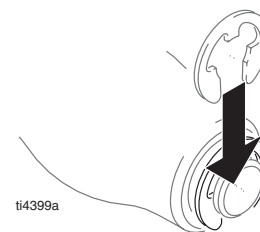

4. Replace back and front covers and hopper. See Removing and Replacing Hopper, Front and Back Cover, page 9.

# Rotor Assembly Replacement

Use Pump Assembly Replacement Kit 287255.

## Disassembly

First read and follow instructions in the **Before performing any service on sprayer** section, page 9.

Then remove hopper, front and back covers, page 9.

Remove hose extension and RotoFlex HD Pump assembly from frame, page 11.

1. To prevent rotor assembly from moving, insert a long screw driver or pry bar in the pulley.

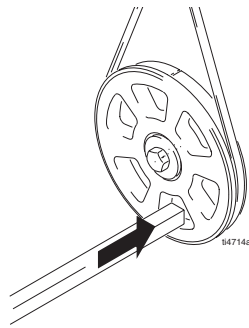

2. Remove large bolt and washer in center of rotor assembly.
3. Pull rotor assembly off shaft.

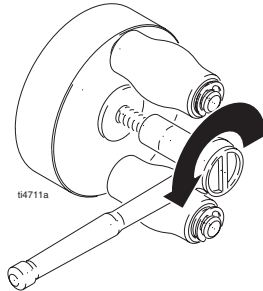

## Reassembly

1. Put new rotor assembly from kit on shaft.
2. Insert a wrench in the pulley to prevent it from moving.

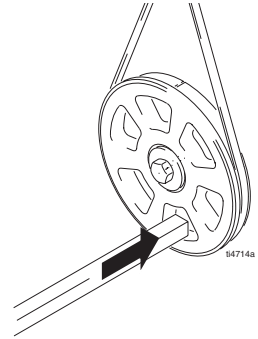

3. Replace bolt. Torque to 40 ft. lb.
4. Replace RotoFlex HD Pump and hose extension, page 12.
5. Replace back and front covers and hopper. See Removing and Replacing Hopper, Front and Back Cover, page 9.

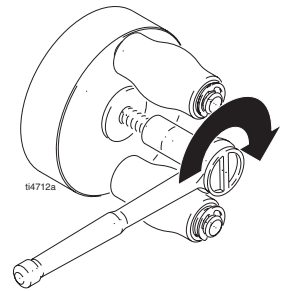

# Air Cylinder and Solenoid Valve

Use Cylinder Replacement Kit, 287323.

For 120 V sprayer use Solenoid Replacement Kit 15D560.

For 230V sprayer use Solenoid Replacement Kit 287351.

## Disassembly

First read and follow instructions in the **Before performing any service on sprayer** section, page 9.

Then remove hopper, front and back covers, page 9.

Remove hose extension and RotoFlex HD Pump assembly from frame, page 11.

1. Remove hose from quick release fitting by using your fingers on one hand to push in on ring while at the same time, using the other hand, gently pull the hose out of the fitting.

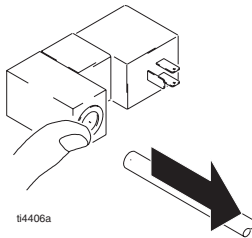

2. Remove electric wire terminal connections.

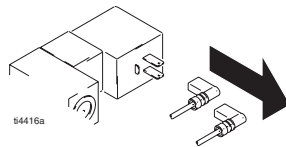

3. Remove cotter key located on the end of the cylinder pin, by using a pliers to straighten the ends and pull it out of the hole.

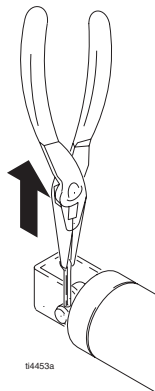

4. Gently push cylinder forward, relieving tension on pin. Pull out pin.

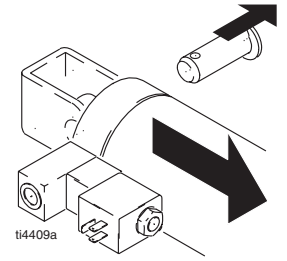

**NOTE:** If replacing solenoid valve only, it can be done at this time.

- a. Use adjustable wrench to rotate entire solenoid valve assembly counterclockwise from cylinder.
- b. Replace solenoid valve and continue with step 4 of reassembly.

5. Lift cylinder up and pull it back.

6. Remove dampening grommet.

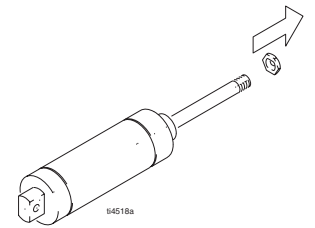

7. Using a 15/16 in. wrench, loosen nut, located inside sprayer frame at the end of the air cylinder.

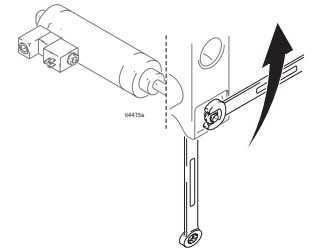

8. Using a 15/16 in. wrench, loosen nut on the other side of the sprayer frame.

9. Pull cylinder out of sprayer frame.

If replacing cylinder only, remove solenoid valve (see a and b above) and reinstall on new cylinder.

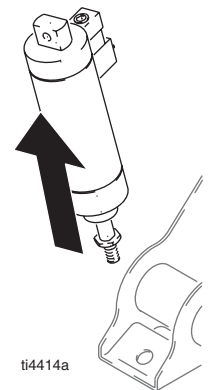

## Reassembly

1. Insert crowned backing nut on shaft of cylinder.
2. Using new cylinder from kit, position cylinder in sprayer frame, inserting end of cylinder through pump bracket mounting hole.

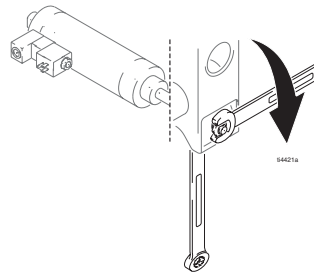

3. Install locking nut flush to end of shaft.
4. Install dampening grommet.
5. Align hole in end of air cylinder and replace pin.

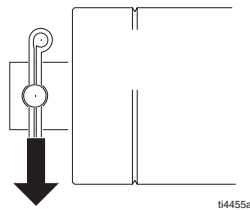
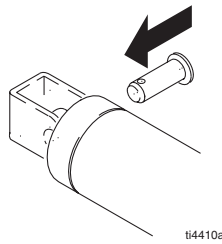

6. Replace cotter pin through hole in pin, bending ends to secure.

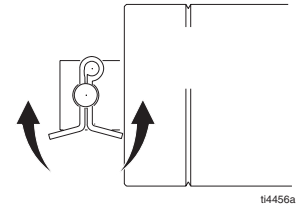

7. Reattach electric wire terminals. Terminals are not polarity sensitive and can be connected to either post.

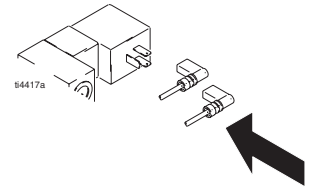

8. Gently push hose in quick release fitting.

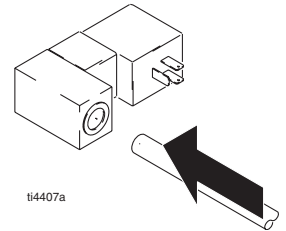

9. Replace RotoFlex HD Pump and hose extension, page 12.

10. Replace front cover and hopper. See Removing and Replacing Hopper, Front and Back Cover, page 9.



# Relief Valve and Flow Sensor Manifold

For 120 V sprayer use Relief Valve Replacement Kit 15D559.

For 230 V sprayer use Relief Valve Replacement Kit 287350.

## Disassembly

First read and follow instructions in the **Before performing any service on sprayer** section, page 9.

Then remove hopper, front and back covers, page 9.

1. Remove air line to regulator.
2. Remove air line from cooler to manifold.
3. Disconnect wires to Relief Valve. Pay attention to their location to insure they are reattached correctly.

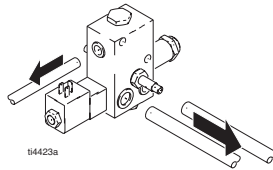

4. Remove 2 nuts securing Relief Valve to sprayer.

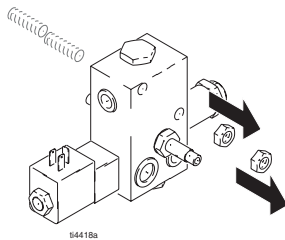

5. Remove Relief Valve from sprayer frame.

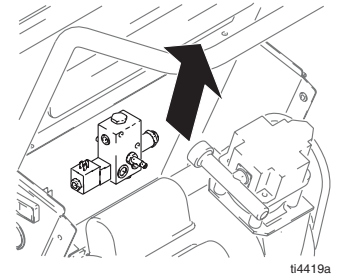

## Reassembly

1. Position new relief valve from Kit in back of sprayer.
2. Replace and tighten screws.
3. Reattach wires to Relief Valve.
4. Reattach air line from cooler to manifold.
5. Reattach air line to regulator. Replace RotoFlex HD Pump and hose extension, page 12.
6. Replace front cover and hopper. See Removing and Replacing Hopper, Front and Back Cover, page 9.

# Air Flow Sensor Replacement

For 120 V sprayer use Sensor Replacement Kit 287326.

For 230 V sprayer use Sensor Replacement Kit 287345.

**NOTE:** If you are just replacing the sensor, you do not have to remove the motor first.

## Disassembly

First read and follow instructions in the **Before performing any service on sprayer** section, page 9.

Then remove hopper, front and back covers, page 9.

Remove hose extension and RotoFlex HD Pump assembly from frame, page 11.

1. Disconnect all wire connections.

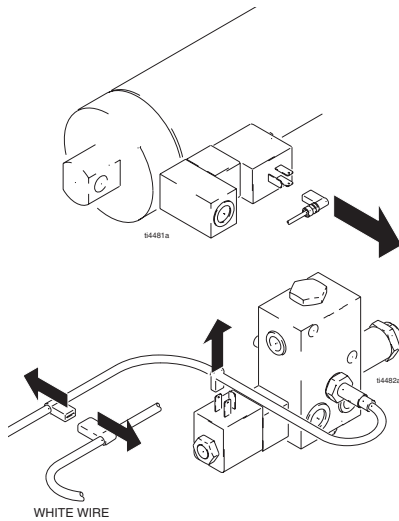

2. Rotate counter-clockwise to remove sensor from manifold.

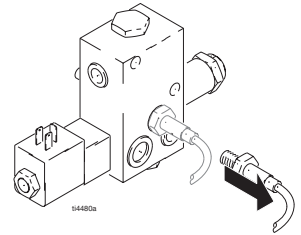

## Reassembly

1. Rotate new sensor from kit clockwise, all the way into opening in Relief Valve housing. Lightly tighten nut.

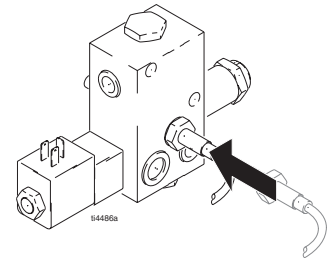

2. Reconnect all wires.
3. Replace RotoFlex HD Pump and hose extension, page 12.
4. Replace back and front covers and hopper. See Removing and Replacing Hopper, Front and Back Cover, page 9.

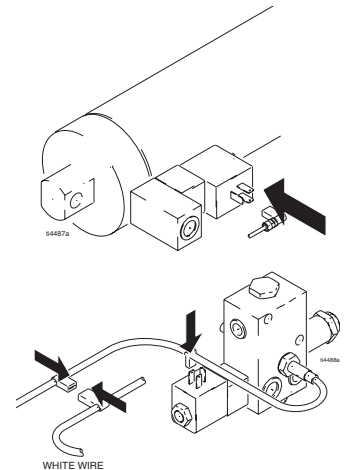

# Troubleshooting



Problem	Cause	Solution
Sprayer won't run or stops intermittently	Power switch not on	Turn switch on.
	No power at wall outlet	Check outlet by plugging in another appliance. If appliance does not work, try another outlet.
	Wrong size generator	Use a 7500 watt or larger generator. Refer to Generator Requirements, page 8.
	Temperature too cold	Allow unit to warm up.
	Too many items on same circuit	Unplug other items from circuit.
	Internal thermal switch tripped	Self-resetting. Allow unit to cool down 15 minutes and restart. Usually occurs when wrong size extension cord is used.
	Extension cord too long or wrong gauge	Use a 12 gage extension cord or remove extension cord. Refer to Grounding and Electric Requirements, page 7.
	Breaker tripped	Reset breaker.
Pump won't pump material or low output	Air lock	Open air valve on gun.
	Mix too thick	Add water to thin material. Use Material Thickness Gauge.
	Loose fittings	Check and retighten all fittings.
	Plugged gun	<b>Relieve Pressure</b> , page 7. Remove gun from hose. Clean gun.
	RotoFlex HD Pump worn out	Replace hose.
	Pump cold or material frozen in pump	Move pump to warm room and allow it to warm up or run hot water through sprayer.
	Sensor is bad	Replace, page 26
	Check air system for leaks	Remove shroud and examine for air leaks
	Loose wire	Remove shroud and examine wiring
	No air pressure	Rebuild compressor

<b>Problem</b>	<b>Cause</b>	<b>Solution</b>
Soft start won't work/pump, always loaded	Sensor is bad	Change sensor, page 26
	Air leak due to bad seal keeps valve open	Replace seal
	Normal soft start system delay	Release trigger for 10-15 seconds. Retry.
	Switch is not operating properly	Replace switch
	Damaged solenoid valve on cylinder	Check gun supply, hose and sprayer for leaks
	Air leak	
Material runs out of bottom of sprayer	RotoFlex HD Pump worn out	Replace hose.
	Loose fittings	Check and retighten all fittings.
No air from compressor	Gun air valve closed	Open gun air valve.
	Gun needle plugged	Clean needle and retry.
	Lines not connected	Check all quick disconnect connections to gun and hoses.
	Damaged hose	Replace hose.
	Worn compressor	Service compressor. Contact a qualified Graco Service Center.
Speed of application too slow	Material too thick	Thin material.
	Nozzle too small	Change nozzles to a larger size. See Operation Manual, Recommended Nozzle Selection Chart, page 20.
Speed of application too slow (cont.)	Flow control set too low	Increase flow control setting
	Plugged or dirty gun	<b>Relieve Pressure</b> , page 7. Clean gun.
	Kinked hose	Unkink hose.
	Gun fluid flow adjustment set too low	Increase flow adjustment with flow adjustment nut.
Intermittent flow/sputtering or air in material	Hopper connection not tight	Check gasket. Tighten connection.
	Debris in system	Clean
Air quick disconnect does not stay connected.	Dirty or corroded fitting	Clean thoroughly. Soak in oil. Apply a few drops of light oil.
Gun will not shut off	Worn nozzle or needle.	<b>Relieve Pressure</b> , page 7. Replace worn parts.
	Debris in needle passage	<b>Relieve Pressure</b> , page 7. Clean.
Fluid leaking at Flow Adjustment Nut	Damaged seal.	<b>Relieve Pressure</b> , page 7. Replace seal.
Needle adjustment won't adjust	Dirty threads	Clean threads
	Nozzle not on gun	Put nozzle on gun
	Flow nut set to maximum adjustment	Turn flow nut adjustment the other way

# Air Diagram

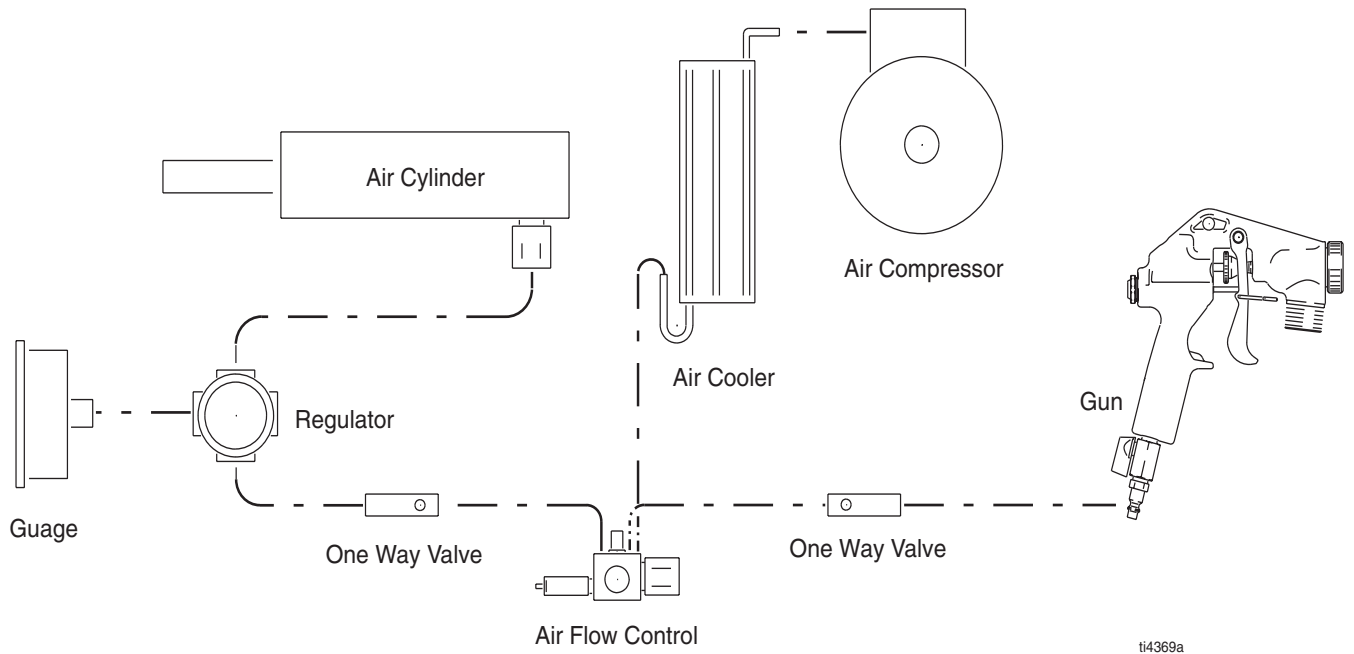

# Wiring Diagram

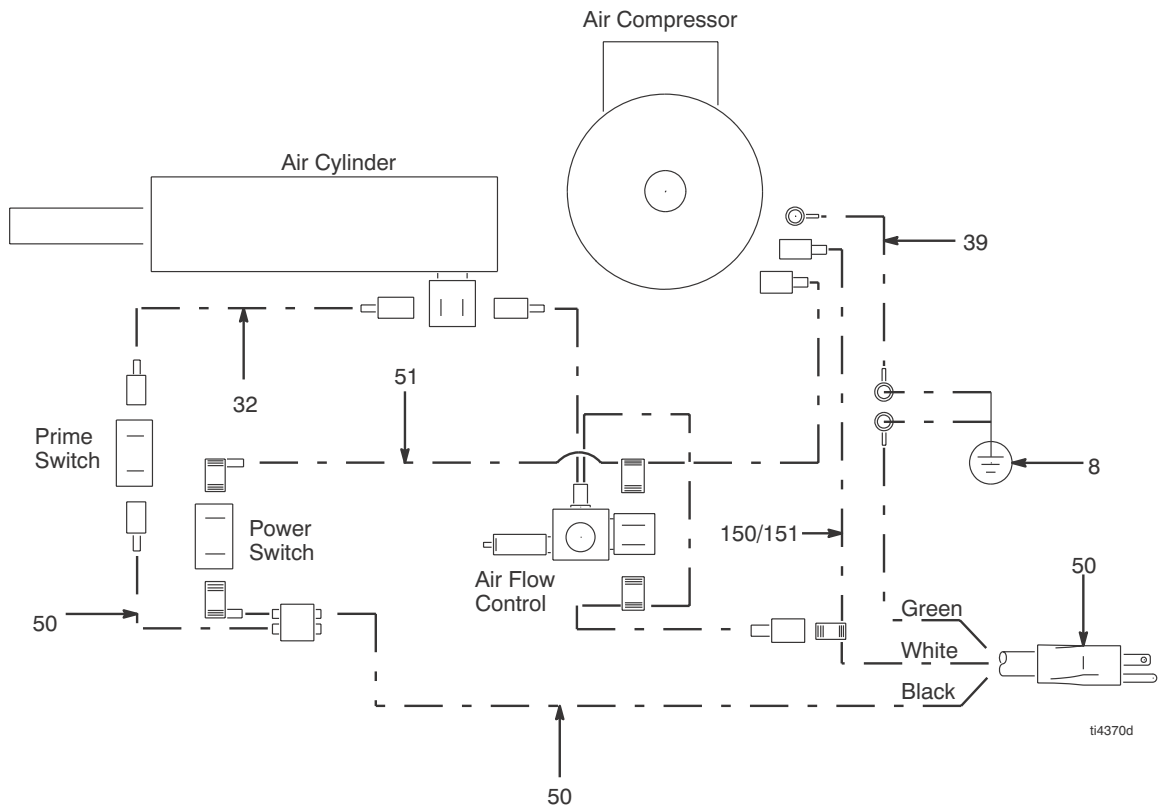



# Parts List

Ref.	Part	Description	Qty	Ref.	Part	Description	Qty
1	287315	KIT, compressor replacement (includes 1A and 1B-1E), 120V sprayers	1	40	103785	RIVET	2
	287330	KIT, compressor rebuild, 120V sprayers		41	287327	KIT, repair, shaft, bracket, pump assbly.	1
	287344	KIT, compressor replacement (includes 1A, and 1B-1D), 230V sprayers		42	287256	BRACKET, compressor	1
	287331	KIT, compressor rebuild, 230V sprayers		43	118869	TUBE	1
1A	119872	SCREW, shoulder	3	45	15D610	SHAFT, motor, mount	1
1B	118886	GROMMET, isolator	3	49	287346	SHIELD, rear, assbly (includes 19, 49A, 49B, 49C)	1
1D	119381	COVER, terminal	1	49A	15D561	COVER, tool tray	1
1E	121479	CAPACITOR, start	1	49B▲	15D939	LABEL, warning, English, French, Spanish	
4	118845	BELT	1		287336	KIT, label, warning, all languages except those included in 15D939	
9	117728	FITTING, compression, union	2	49C▲	15D940	LABEL, identification	
13	15D156	PULLEY, rotor	1	51	15D634	WIRE, jumper	1
16	118888	HOSE, air (includes 1/4 in. tubing and one-way valve)	1	52	116937	BEARING, flanged, bronze	2
19	15D862	NUT, hand	1	53	117633	SCREW, slot hex wash hd	8
21	118876	TUBE, air, aluminum	1	54	116666	TUBE, air	1
22	117637	NUT, compression	1	55	287304	HOSE SET, twin line, 1 in. x 25-ft	1
31	112395	SCREW, cap	4	56	15C090	GAUGE, thickness, fluid	1
32	15D633	WIRE, jumper	1	57	183401	KEY, parallel	2
33	103473	STRAP, tie, wire	2	58	116720	COUPLER, air, quick disconnect	1
34	15B815	COOLER	1	62	108851	WASHER, plain	2
36	101242	RING, retaining, ext.	2	63	106276	SCREW, cap, hex head	2
37	287255	ROTOR, pump, assbly (includes 38, 38A, 38B)	1	67	248515	BALL, sponge, 30 mm (5 pk)	2
38	287321	KIT, roller replacement (includes 38A, 38B and two rollers)	2	73	112785	SCREW, flanged, hex head	2
38A	113983	RING, retaining, ext	2	74	115498	SCREW, mach, slot, hex, wash hd	1
38B	117726	WASHER, nylon	4	82	118887	HOSE, air (includes 1/4 in. tubing and one-way valve)	1
39	15D628	CONDUCTOR, ground	1	88	118866	WASHER, flat	1
				101	248091	GUN, non-bleeder	1
				102	122104	VALVE PLATE, compressor	1

▲ Replacement Danger and Warning labels, tags and cards are available at no cost.

# Parts

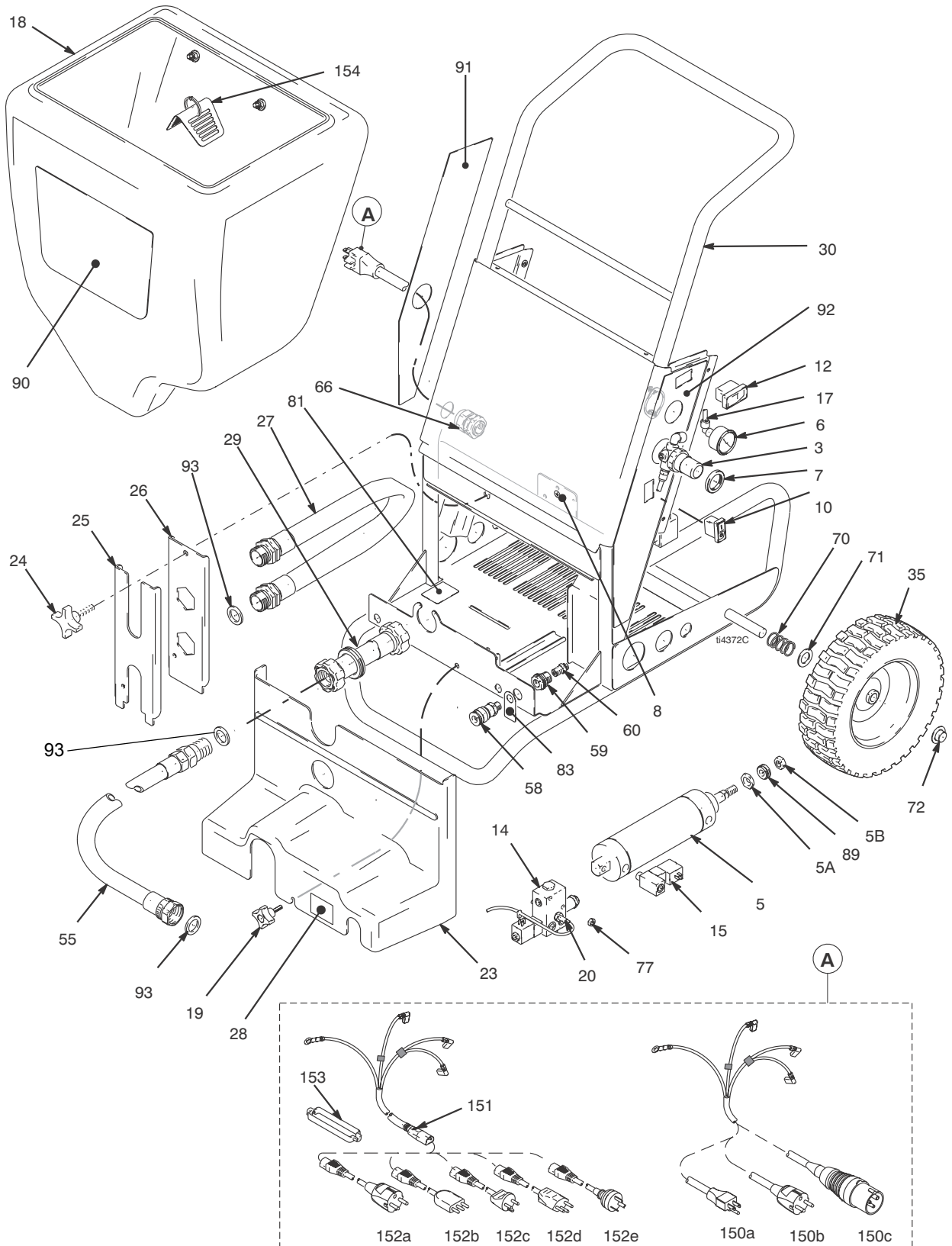



# Parts List

Ref.	Part	Description	Qty	Ref.	Part	Description	Qty
3	118844	REGULATOR, air, 1/8 in. NPT	1	49C▲	15D940	LABEL, identification	
5	287323	KIT, cylinder, replacement, (includes 5A, 5B, 89)	1	51	15D634	WIRE, jumper	1
5A	15D576	SPACER, crowned	1	54	116666	TUBE, air	1
5B	118871	NUT, lock, 1/2-20	1	55	287304	HOSE SET, twin line, 1 in. x 25-ft	1
6	117720	GAUGE, pressure	1	58	116720	COUPLER, air, quick disconnect	1
7	115244	NUT, regulator	1	59	104641	FITTING, bulkhead	1
8▲	186620	LABEL, ground, symbol	1	60	116658	FITTING, tube, male, 1/4 NPT	1
10	117693	SWITCH, power	1	66	116171	BUSHING, strain relief	1
12	119064	SWITCH, power, prime	1	70	116411	SPRING, compression	2
14	15D559	VALVE, assembly, 120V (includes sensor) sprayer	1	71	116477	WASHER, flat, nylon	2
	287350	VALVE, assembly, 230V (includes sensor) sprayer	1	72	101242	CAP, end	4
15	15D560	VALVE, cylinder, 120V sprayer	1	74	115498	SCREW, mach, slot, hex, wash hd	1
	287351	VALVE, cylinder, 230V sprayer	1	77	102040	NUT, lock, hex	2
16	118888	HOSE, air (includes 1/4 in. tubing and one-way valve)	1	81▲	198492	LABEL, warning	2
17	15C968	TUBE, air	1	82	118887	HOSE, air (includes 1/4 in. tubing and one-way valve)	1
18	287347	HOPPER, texture (includes bracket)	1	83▲	15D089	LABEL, warning, hot surface	1
19	15D862	NUT, hand	1	89	801012	GROMMET	1
20	287326	KIT, sensor only, 120V	1	90▲	15D951	LABEL, identification	1
	287345	KIT, sensor only, 230V	1	91▲	15D953	LABEL, identification	1
23	287348	SHIELD, front (includes 28)	1	92▲	15D952	LABEL, identification	1
24	108471	KNOB, pronged	1	93	118872	GASKET	4
25	15D589	BRACKET, hose, outer	1	150		CORD, power	
26	15D588	BRACKET, hose, inner	1	150a	15D630	Americas/Canada, 120V, 60 Hz	1
27	287314	KIT, RotoFlex HD Pump	1	150b	15E056	Europe/Asia, 230V, 50 Hz (hardwired, rubber cord)	1
28▲	189286	LABEL, warning	1	150c	15E061	United Kingdom, 110V, 60, Hz	1
29	118885	HOSE, coupled (includes grom- met)	1	151	15D902	CORD, power, Europe/Austra- lia/China, 230V, 50 Hz (requires cordset adapter, 152, following)	1
30	287254	FRAME, texture, blue	1	152		ADAPTER, cordset, (for 15D902),	
32	15D633	WIRE, jumper	1	152a	242001	Europe	1
35	116478	WHEEL, pneumatic	2	152b,c,d	287121	Italy, Denmark, Switzerland	1
49B▲	15D939	LABEL, warning, English, French, Spanish		152e	242005	Australia/China	1
	287336	KIT, label, warning, all languages except those included in 15D939		153	195551	RETAINER, (for 15D902)	1
				154	15F966	BAFFLE, hopper	1

# Technical Data

Maximum working fluid pressure	100 psi (6.9 bar)
Maximum working air pressure	45 psi (3.1 bar)
Material pressure operating range	0-100 psi (0 to 6.9 bar)
Compressor	
Type	Oilless
Air delivery	6.5 CFM @ 40 psi (184.1 lpm @ 2.8 bar)
Motor	
	120V, 60 Hz 15A
	230V, 50 Hz 10A
Hopper capacity	15 US gallons (57 liters)
Maximum delivery with texture material	2.0 gpm (7.57 lpm)
Dimensions	
Length	27 in. (685.8 mm) with handles
Width	26 in. (660.4 mm)
Height	40 in. (1016 mm)
Weight	
With hoses and gun	147 lb (66.68 kg)
Without hoses and gun	131 lb (59.47 kg)
Wetted parts	PVC, Buna-N, anodized aluminum, powder coat aluminum, brass, polyethylene, SST, UHMW
Sound data	
Sound pressure level*	85.8 db(A)
Sound power level#	100.1 db(A)
Generator (minimum size requirement)	7500W (7.5 kW)
Maximum external working air pressure (must use <i>External Air Hookup Kit 287328 ONLY</i> )	120 psi (8.3 bar)

\*Measured while spraying at 1 m.

#Measured per ISO-3744



# Стандартная гарантия компании Graco

Компания Graco гарантирует, что во всем оборудовании, упомянутом в настоящем документе, произведенном компанией Graco и маркированном ее наименованием, на момент его продажи первоначальному покупателю отсутствуют дефекты материала и изготовления. За исключением любых специальных, расширенных или ограниченных гарантий, публикуемых компанией Graco, в период двенадцати месяцев с момента приобретения оборудования, любая деталь, которая будет признана компанией Graco дефектной, будет отремонтирована или заменена. Эта гарантия действительна только в том случае, если оборудование устанавливается, эксплуатируется и обслуживается в соответствии с письменными рекомендациями компании Graco.

Ответственность компании Graco и настоящая гарантия не распространяются на случаи общего износа оборудования, а также на любые неисправности, повреждения или износ, возникшие в результате неправильной установки или эксплуатации, абразивного истирания, коррозии, недостаточного или неправильного обслуживания оборудования, проявлений халатности, несчастных случаев, внесения изменений в оборудование или применения деталей, производителем которых не является компания Graco. Кроме того, компания Graco не несет ответственность за неисправности, повреждения или износ, вызванные несовместимостью оборудования Graco с конструкциями, принадлежностями, оборудованием или материалами, которые не были поставлены компанией Graco, либо неправильным проектированием, изготовлением, монтажом, эксплуатацией или техническим обслуживанием конструкций, принадлежностей, оборудования или материалов, которые не были поставлены компанией Graco.

Настоящая гарантия действует при условии, что оборудование, в котором предполагается наличие дефектов, было предоплаченным отправлением возвращено уполномоченному дистрибьютору Graco для проверки заявленного дефекта. Если факт наличия предполагаемого дефекта подтвердится, компания Graco обязуется бесплатно отремонтировать или заменить любые дефектные детали. Оборудование будет возвращено первоначальному покупателю с предоплатой транспортировки. Если проверка не выявит никаких дефектов изготовления или материалов, ремонт будет осуществлен по разумной цене, которая может включать стоимость работ, деталей и транспортировки.

**НАСТОЯЩАЯ ГАРАНТИЯ ЯВЛЯЕТСЯ ИСКЛЮЧИТЕЛЬНОЙ И ЗАМЕНЯЕТ ВСЕ ПРОЧИЕ ГАРАНТИИ, ЯВНО ВЫРАЖЕННЫЕ ИЛИ ПОДРАЗУМЕВАЕМЫЕ, ВКЛЮЧАЯ, ПОМИМО ПРОЧЕГО, ГАРАНТИЮ ТОВАРНОГО СОСТОЯНИЯ ИЛИ ГАРАНТИЮ ПРИГОДНОСТИ ДЛЯ ОПРЕДЕЛЕННОЙ ЦЕЛИ.**

Единственное обязательство компании Graco и единственное средство правовой защиты покупателя в отношении возмещения ущерба за любое нарушение гарантийных обязательств должны соответствовать вышеизложенным положениям. Покупатель соглашается с тем, что никакие другие средства правовой защиты (включая, помимо прочего, случайные или косвенные убытки в связи с упущенной выгодой, упущенными сделками, травмами персонала или порчей имущества, а также любые иные случайные или косвенные убытки) не будут доступны. Все претензии, связанные с нарушением гарантийных обязательств, должны быть предъявлены в течение 2 (двух) лет с момента продажи.

**КОМПАНИЯ GRACO НЕ ПРЕДОСТАВЛЯЕТ НИКАКИХ ГАРАНТИЙ, ЯВНЫХ ИЛИ ПОДРАЗУМЕВАЕМЫХ, ОТНОСИТЕЛЬНО ТОВАРНОЙ ПРИГОДНОСТИ ИЛИ СООТВЕТСТВИЯ КАКОЙ-ЛИБО ОПРЕДЕЛЕННОЙ ЦЕЛИ В ОТНОШЕНИИ ПРИНАДЛЕЖНОСТЕЙ, ОБОРУДОВАНИЯ, МАТЕРИАЛОВ ИЛИ КОМПОНЕНТОВ, ПРОДАВАЕМЫХ, НО НЕ ПРОИЗВОДИМЫХ КОМПАНИЕЙ GRACO.** На изделия, проданные, но не изготовленные компанией Graco (например, электродвигатели, выключатели, шланги и т. д.), распространяется действие гарантий их изготовителей, если таковые имеются. Компания Graco будет в разумных пределах оказывать покупателю содействие в предъявлении любых претензий в связи с нарушением таких гарантий.

Ни при каких обстоятельствах компания Graco не будет нести ответственность за косвенные, случайные, специальные или побочные убытки, связанные с поставкой описанного в этом документе оборудования, а также с предоставлением или использованием любых продаваемых изделий или товаров, которые указаны в этом документе и на которые распространяется действие настоящего документа, будь то в случае нарушения контракта, нарушения условий гарантии, халатности со стороны компании Graco или в иных случаях.

## Информация о компании Graco

Чтобы ознакомиться с последними сведениями о продукции Graco, посетите веб-сайт [www.graco.com](http://www.graco.com).

Сведения о патентах смотрите на веб-сайте [www.graco.com/patents](http://www.graco.com/patents).

ЧТОБЫ РАЗМЕСТИТЬ ЗАКАЗ, обратитесь к своему дистрибьютору компании Graco

**GENERAL ENGINEERING - ОФИЦИАЛЬНЫЙ ДИСТРИБЬЮТОР И СЕРВИСНЫЙ ЦЕНТР  
КОМПАНИИ «GRACO» В РОССИИ**

107023, г.Москва, ул.Малая Семеновская, д.11/2, стр.2, этаж 1, офис 1

тел/факс: +7(495) 540-42-40

[www.gnrg.ru](http://www.gnrg.ru)

e-mail: [info@gnrg.ru](mailto:info@gnrg.ru)